

## **Technical Requirements of Bus for Inter provincial Bus Services**

### **Normal Services**

- Luggage compartment of not less than 1 m<sup>3</sup>.
- Emergency door should be fitted at the rear of the vehicle and the gangway that lead up to the exit without any obstruction.
- The Width of seat cushion shall be 450mm.
- Rexene seats.
- The width of every gangway shall be not less than 305 millimeters.
- All parts of the passenger area should be non slip.
- Suitable power assisted door closure shall be provided to close and hold such doors securely closed.
- The Minimum depth of the seat cushion shall be at least 350 millimeters.
- Accelerated running noise level should be measured in Maximum(Lmax) mode
  - (a) External noise level measured at a distance of 5 m, away from the silencer and exhaust noise should not exceed 82dB.
  - (b) Noise Level inside the passenger cabin should not exceed 80dB.
  - (c)Horn noise level should measure at 5 meters; away from the front buffer noise should not exceed 105dB.
- Passenger information Panel should be at least 18 inch width and 10 inch height and fitted to face seated passengers.
- Two glass Windscreen should be fitted.
- Digital clock should be fitted and the time could be visible to every seating passengers.
- The glass of the windscreen and windows shall be made of safety glass.
- (a)Both front and rear should be in single color.
  - (b)White color is preferable.(Exact color code : Super white 040
- Suitably illuminated Destination indicator boxes should be 1500mm (5ft) in width 300mm (1ft) in height. Destination indicator boxes should be provided at front and rear. Preferably middle upper part of the windscreen.

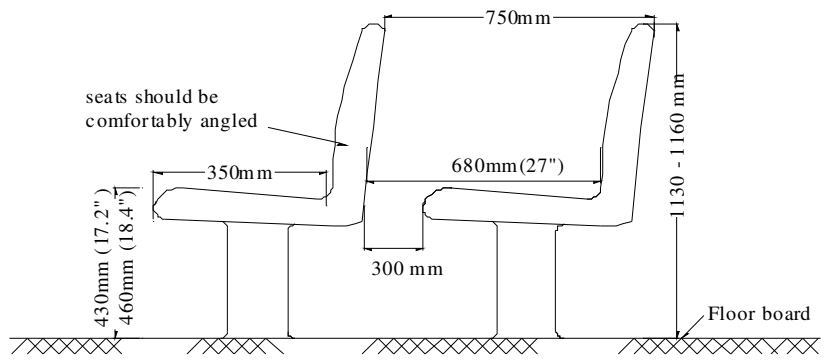

- There is a clear space of at least 680millimeters between the front surface of the seat back measured horizontally and a clear space of at least 300millimetres in front of any part of that seat.